

Product information sheet QUATRUS R15 400-IU

Item no. 526885

Benefits



- Versatile bowl programme for the most diverse requirements
- Elegant flat rim for inset installation and undermounting
- Extra-large and deep bowls for maximum convenience
- Concise corner radii, modern and functional
- Higher functionality thanks to the eye-catching drain grooves in the base

Scope of supply

- waste kit
- 3 ½" basket strainer
- fixing kit

Details

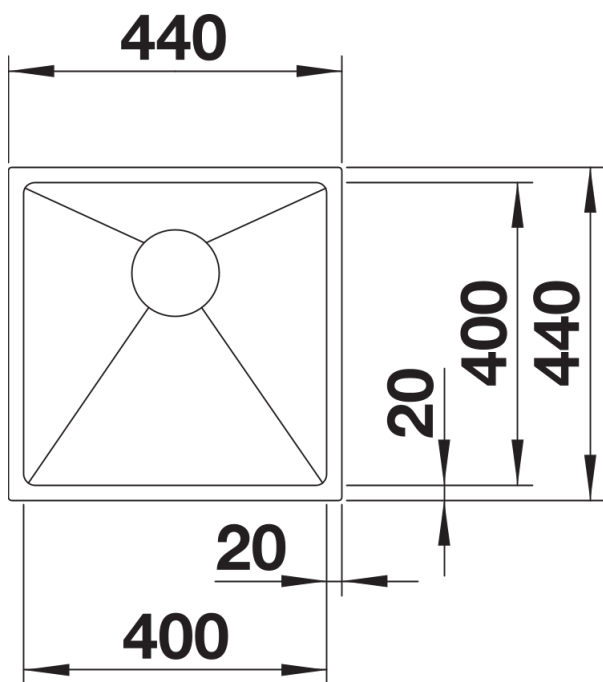

Top view

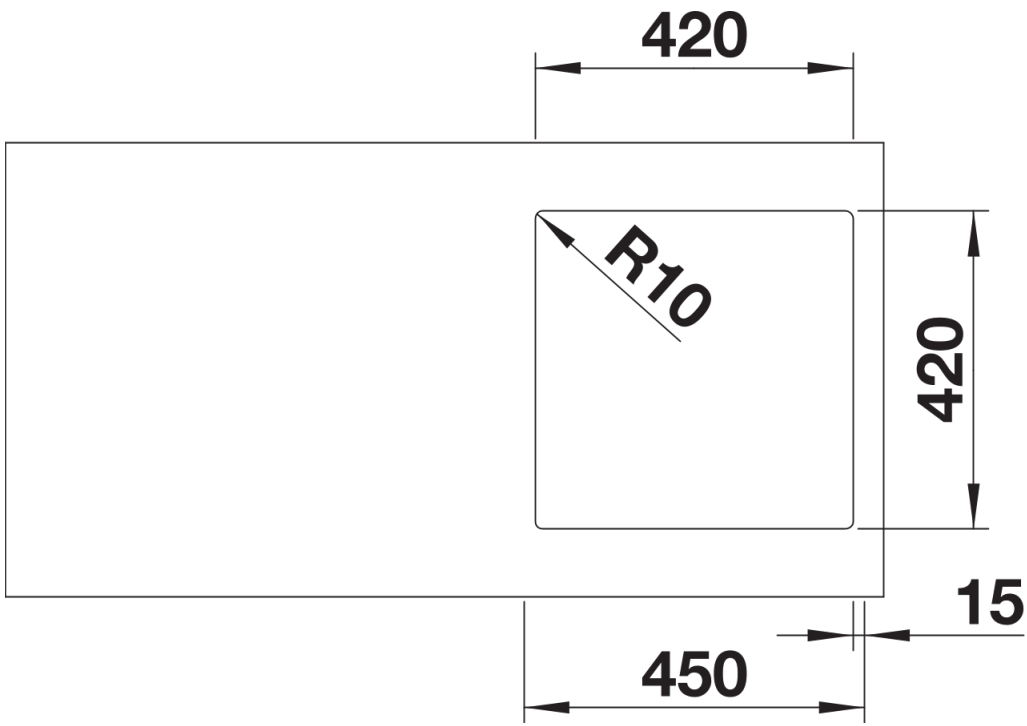

Cut-out

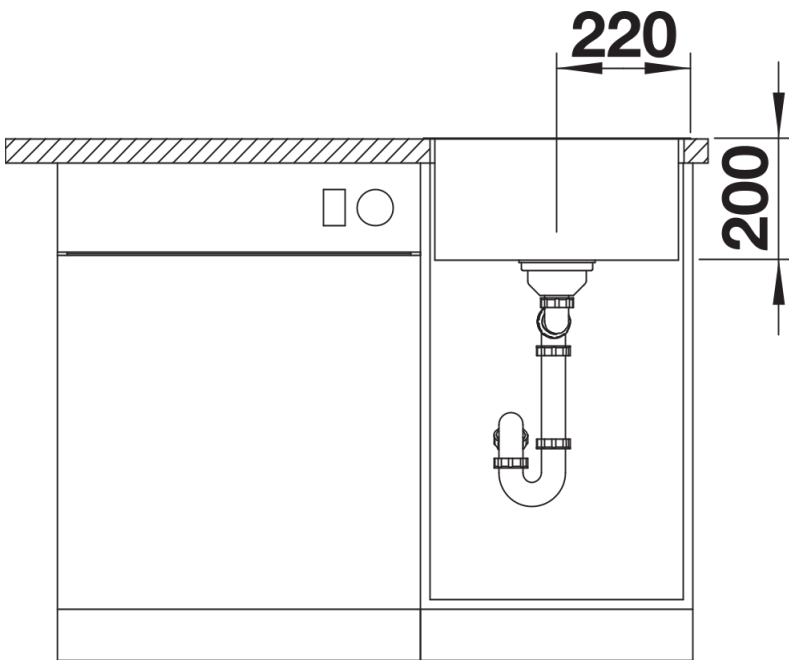

Front view

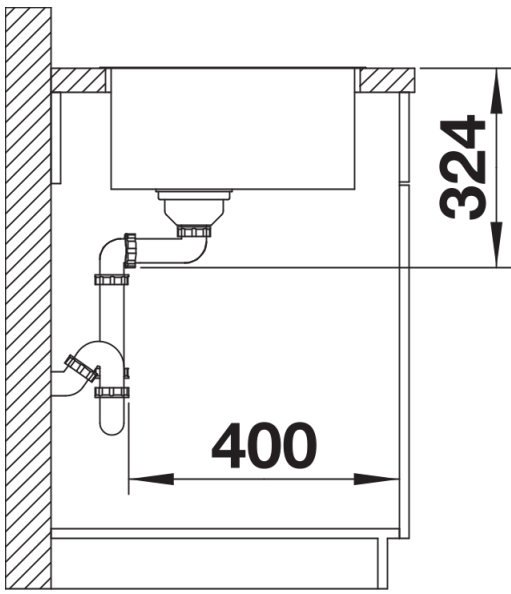

Side view