

Product information sheet ZIA 8 S

Item no. 528037

Benefits



- Modern design with clear lines
- Straight-lined outer contour emphasised by the narrow rim
- Characteristic tap ledge as a frame that enlarges the drainer
- Spacious double bowl sink with drainer provides a high degree of comfort
- Left-hand version

Colours



Available colours:

black
anthracite
white

SILGRANIT anthracite

Scope of supply

- waste kit
- 2 x 3 ½" basket strainer

Details

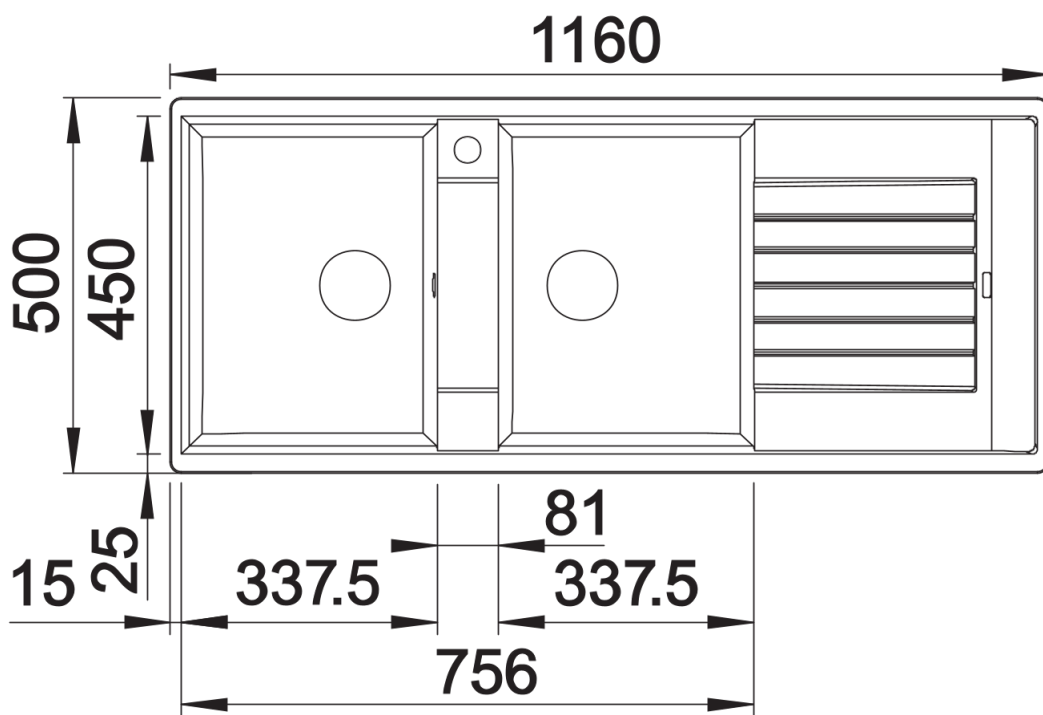

Top view

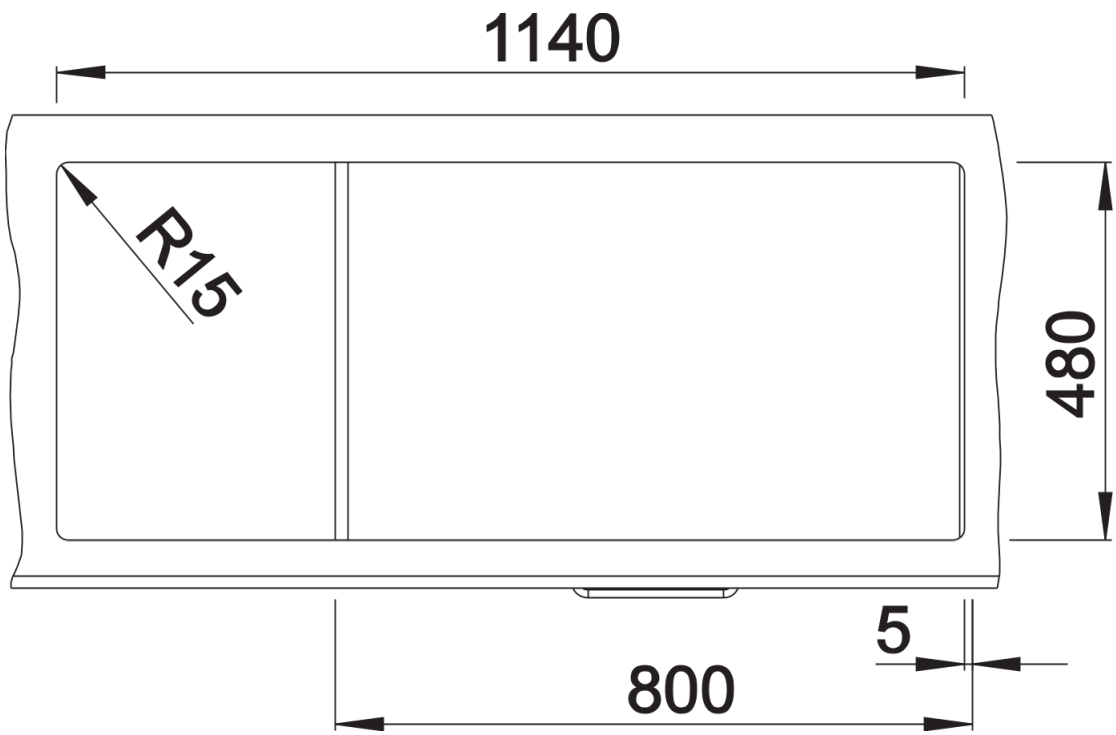

Cut-out

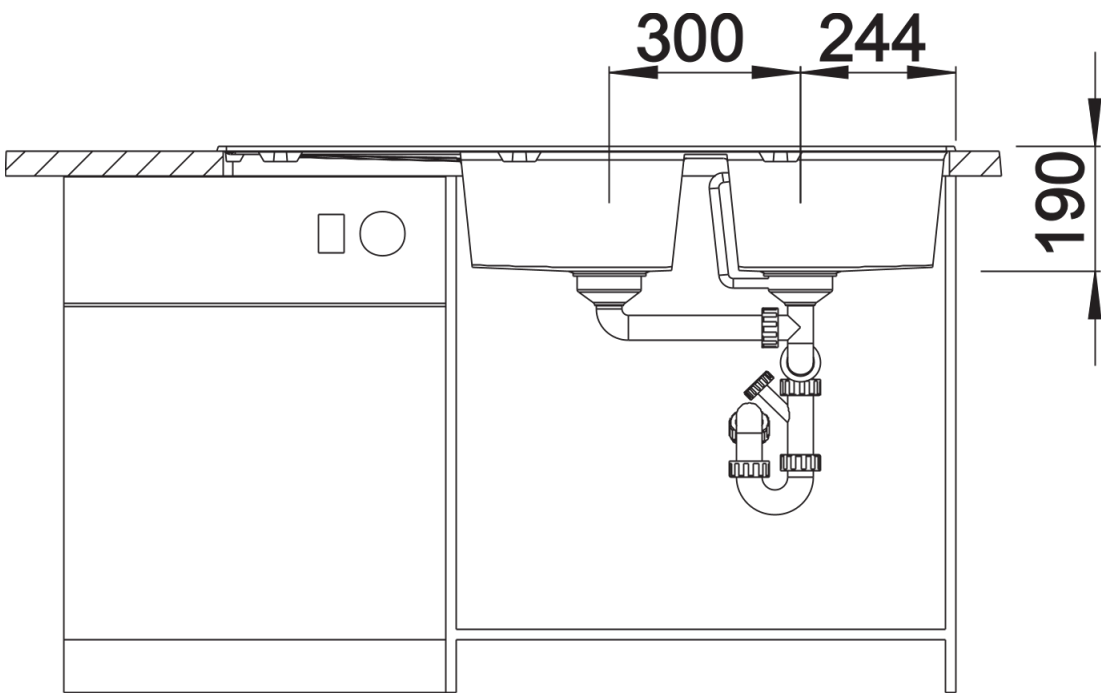

Front view

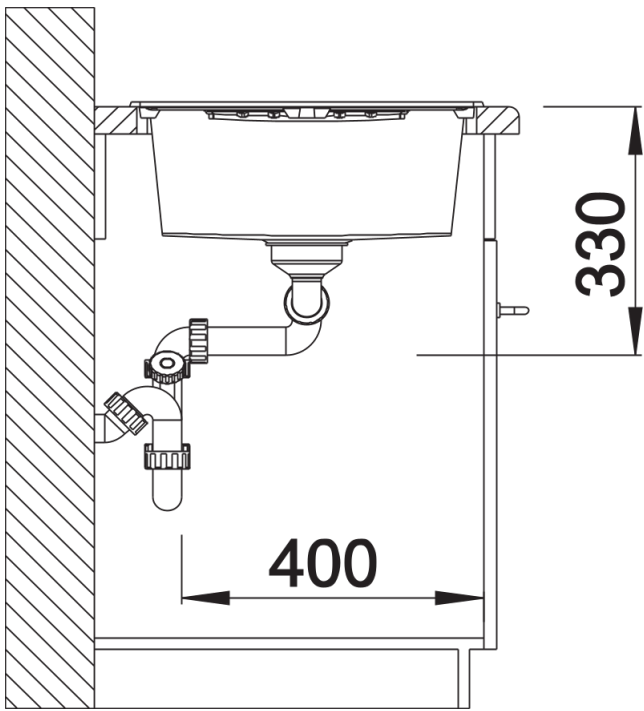

Side view