

Product information sheet VICUS TWIN LEVER

Item no. 524284

Benefits



- Classic design with modern functionality
- High quality ceramic seals and cartridge for extremely long-lasting operation.
- Available in four different finishes

Colours



Available colours:

- chrome
- brushed brass
- pewter
- brushed copper

galvanic chrome

Scope of supply

- Twin lever mixer tap
- High quality ceramic seals and cartridge for extremely long-lasting operation
- Suitable for low pressure gravity and pressurised systems, min 0.3 bar / max 5.0 bar
- Swivel spout with 187 reach

Details

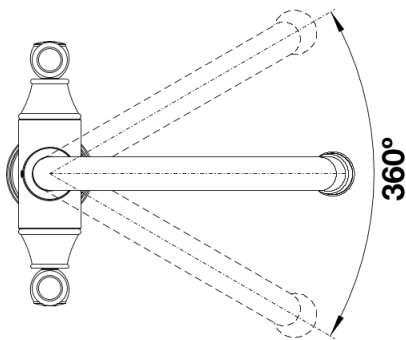

Swivel range

