

Product information sheet VINTERA XL 9-UF

Item no. 526102

Benefits



- Striking sink with farmhouse flair, ideal for modern kitchen designs
- Extra-large bowl provides plenty of room
- Perfect fit: right-angled apron front fits the width of a 90 cm cabinet
- One model for flush-mount or undermount installation

Colours



SILGRANIT rock grey

Available colours:

black
anthracite
rock grey
volcano grey
white
soft white
tartufo
coffee

Planning information

- Please note the installation details and cut-out information for:
Flushmount: <https://youtu.be/CGRIPZsbQ6Y>
Undermount: <https://youtu.be/jB-uTpOrpCc>

Scope of supply

- waste kit with space-saving pipe
- 3 ½" InFino basket strainer

Details

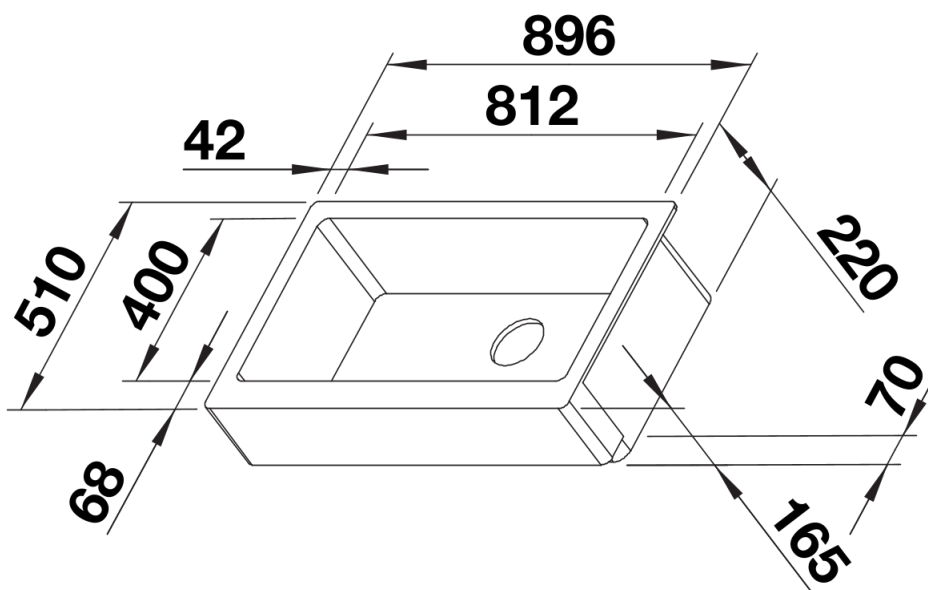

Top view

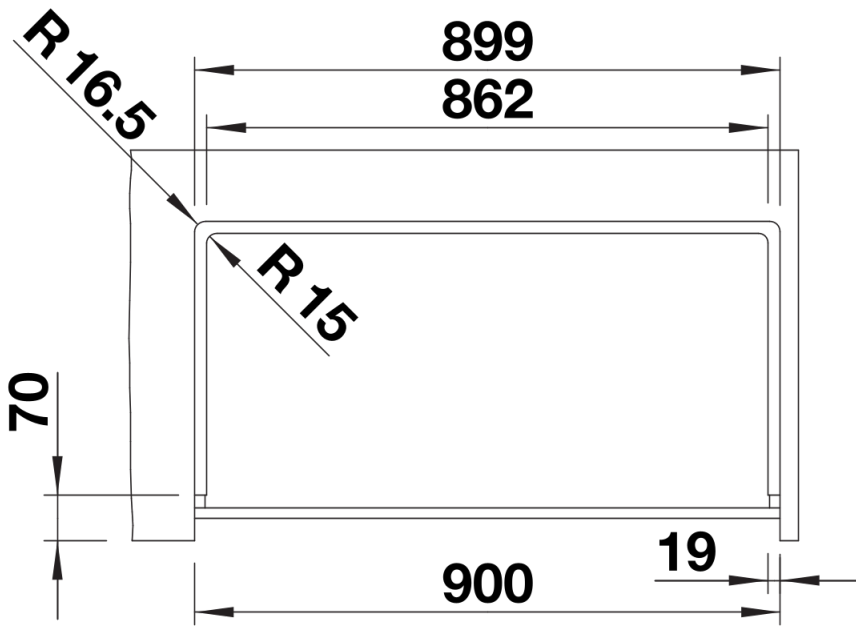

Cut-out

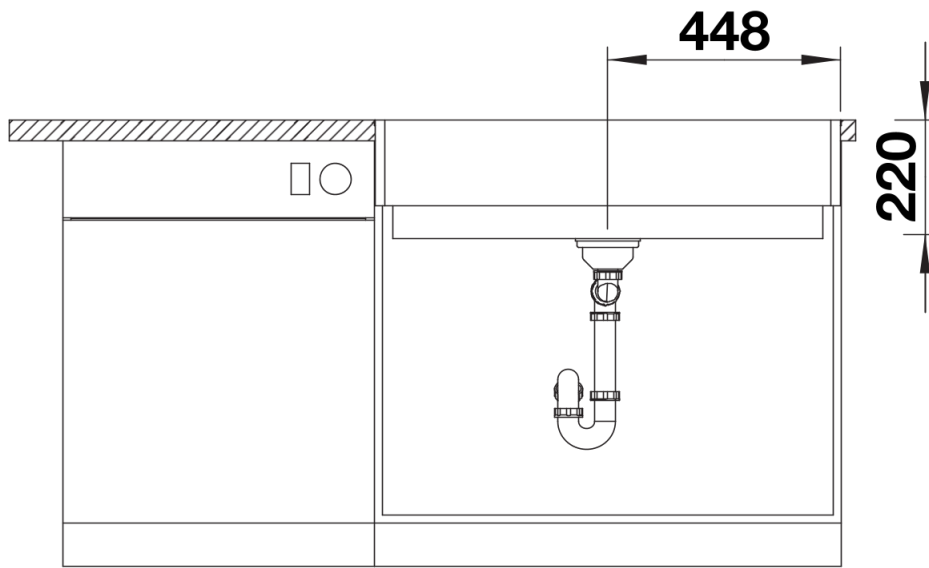

Front view

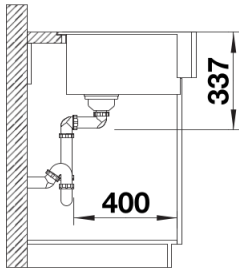

Side view