

## Product information sheet ETAGON 500-IF/A

Item no. 521748

### Benefits

---



- Generous staggered bowl with added functionality
- Integrated step creates an additional functional level
- Clever system concept with versatile ETAGON rails
- High-quality features with the covered C-overflow and InFino drain system – elegantly integrated and easy-care

## Planning information

---

- Additional drill hole possible. The subsequent drill hole should be carried out by a specialist company.

## Scope of supply

---

- 2 x ETAGON rails in stainless steel
- waste kit with space-saving pipe
- 3 ½" InFino basket strainer with drain remote control (pop-up chrome-plated)
- fixing kit

234164 - 2 x ETAGON rails

## Details

---

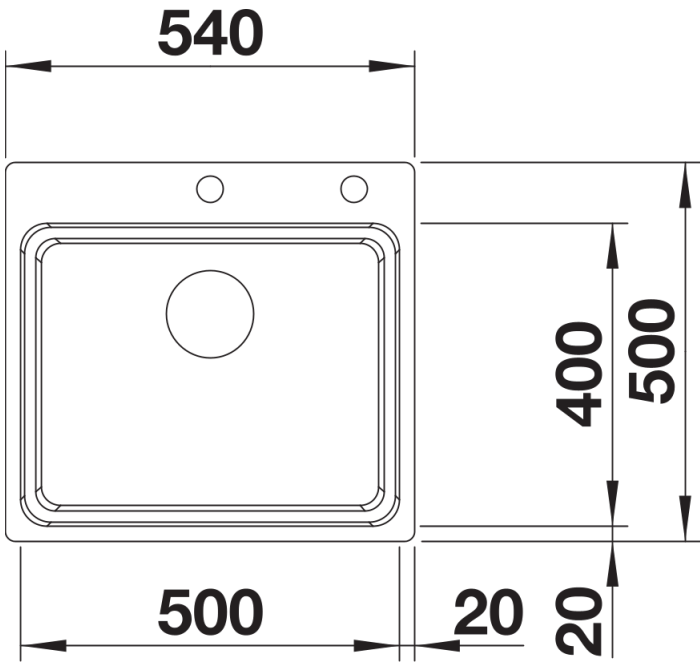

Top view

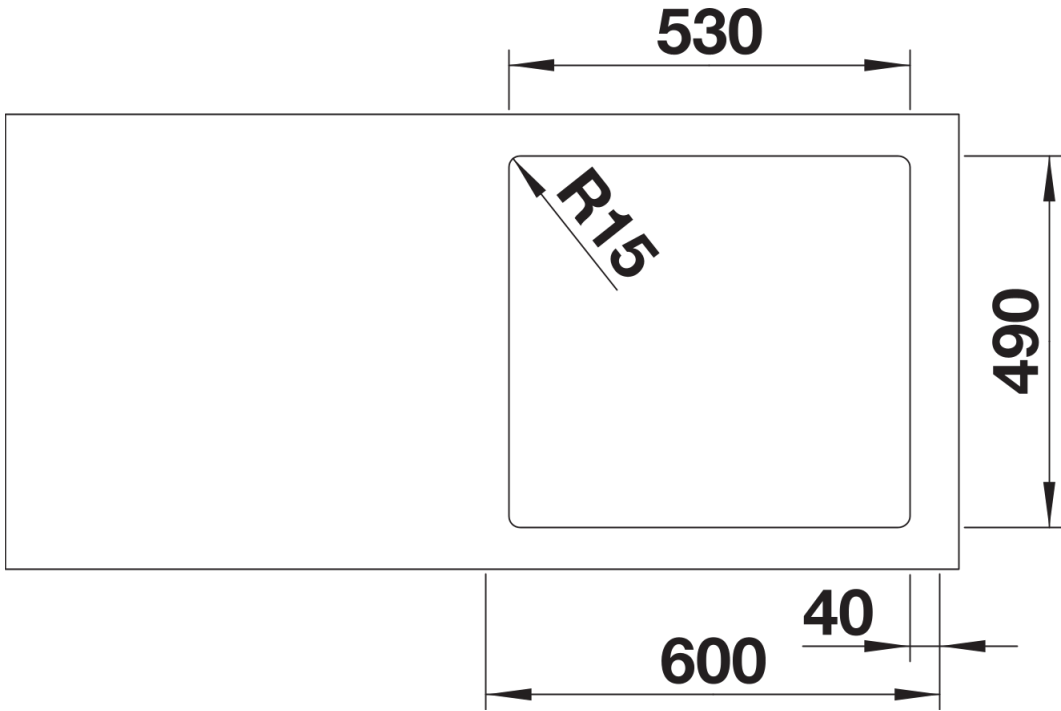

Cut-out

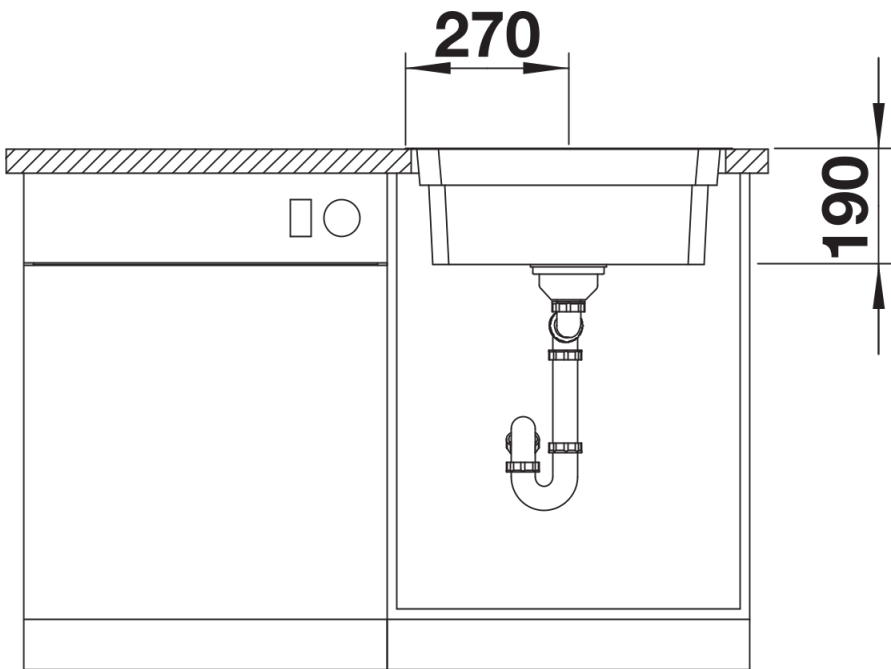

Front view

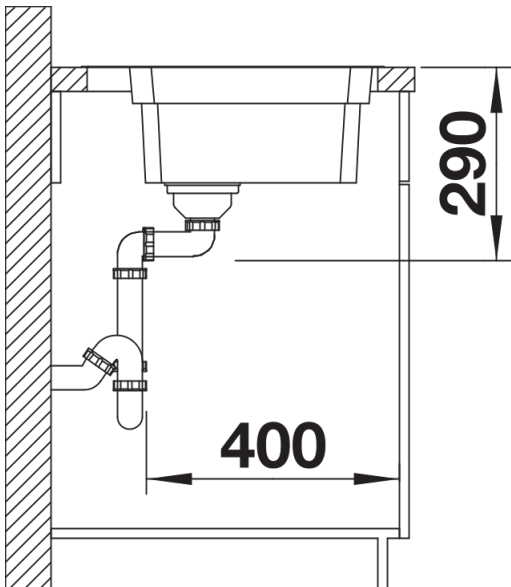

Side view