

Product information sheet ZEROX 700-IF/A Durinox

Item no. 523102

Benefits



- Zero radius design with the striking rectangular bowl geometry
- Matt velvet look with a homogeneous surface structure and pleasantly warm to the touch
- Highly resistant to scratches
- With the covered C-overflow in Durinox
- InFino drain system with PushControl - the slim and intuitive remote control
- Augmented stability of the mixer tap due to the extensive stabilising technology

Scope of supply

- waste kit with space saving pipe
- 3 ½" InFino basket strainer with drain remote control (PushControl)
- fixing kit

Details

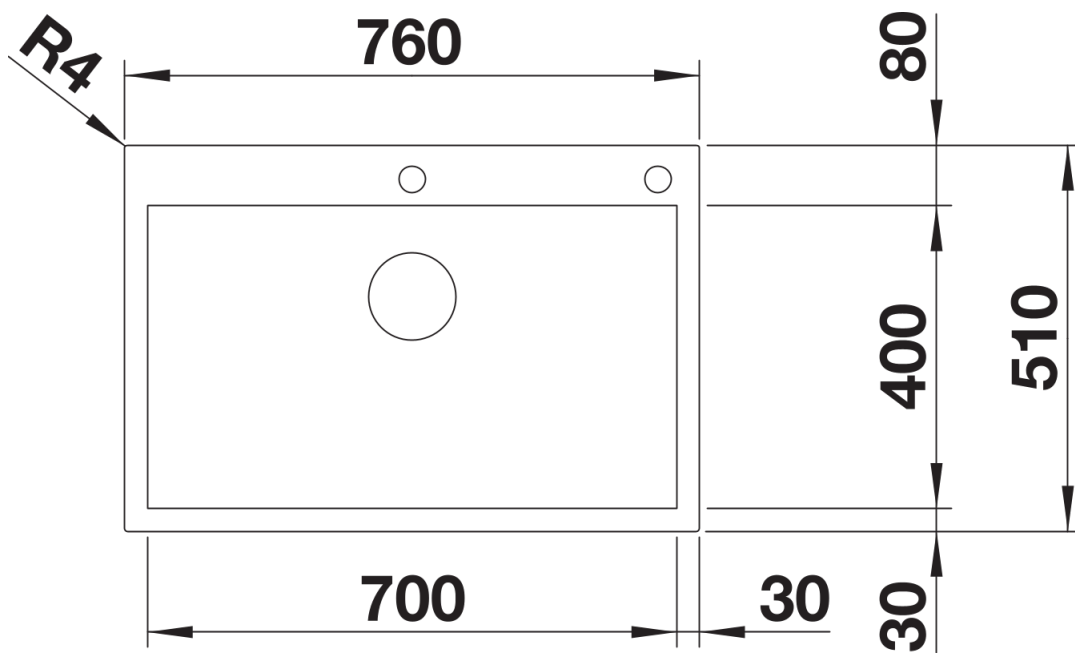

Top view

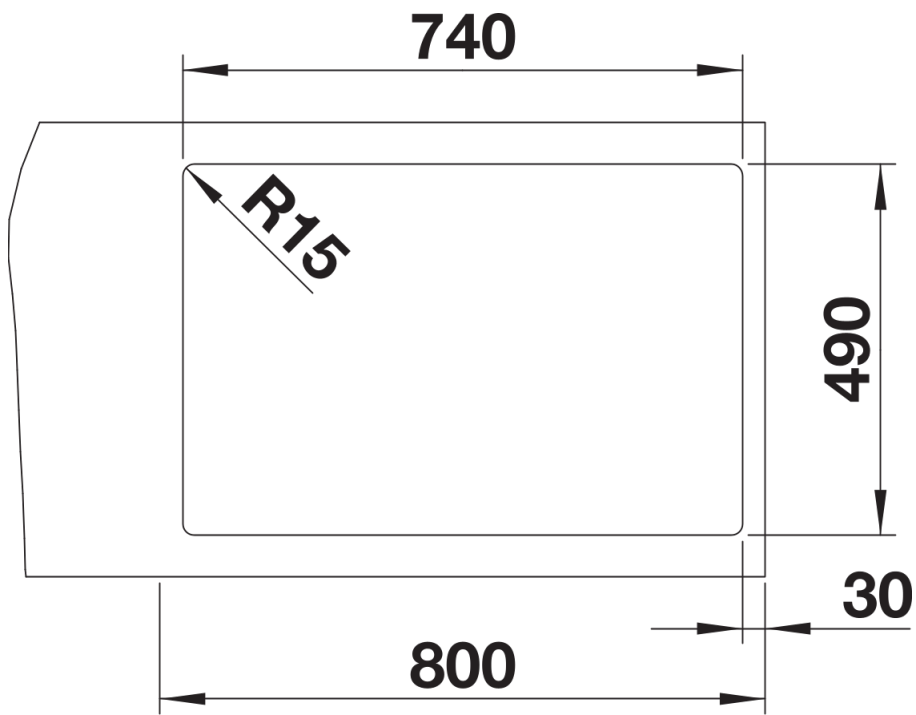

Cut-out

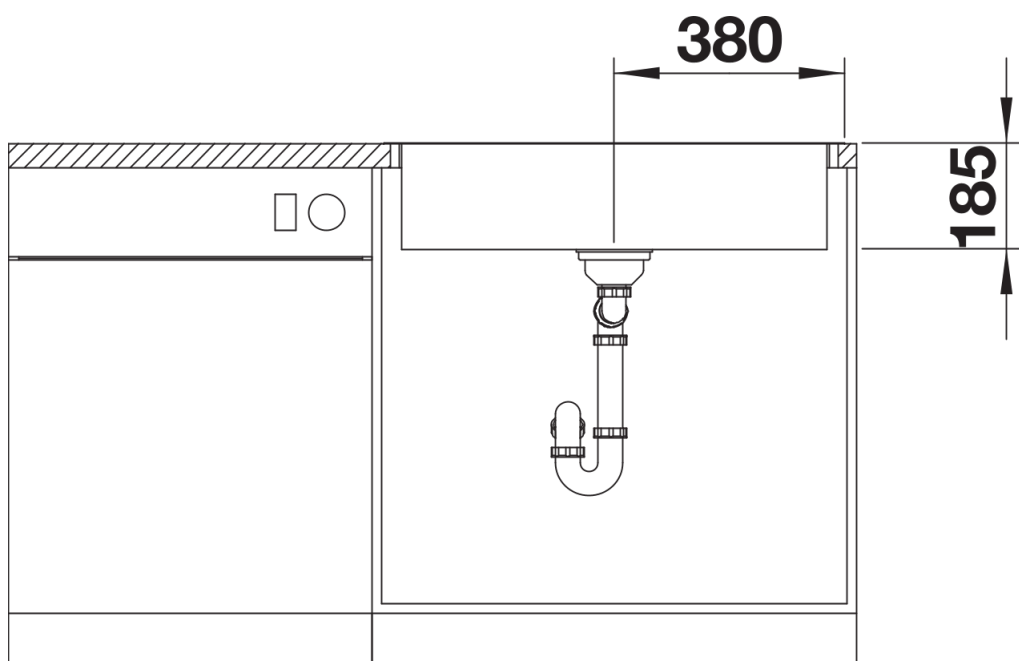

Front view

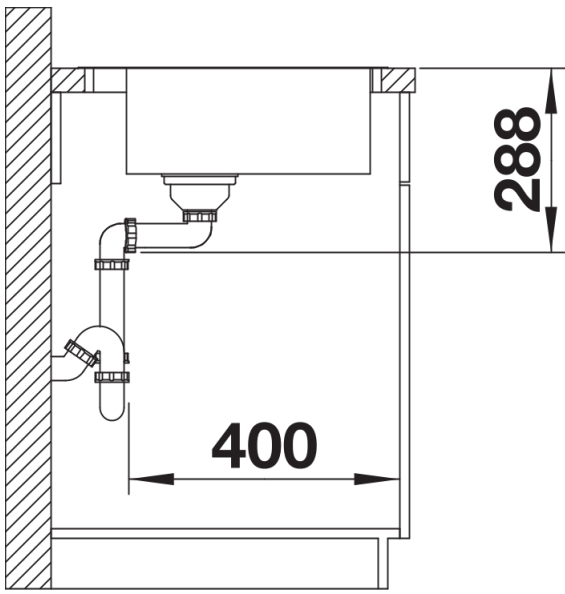

Side view